

PARTS MANUAL

**H400HD, H400HDS, H450HD,
H450HDS
(A236)**

CUSTOMER EDITION

HYSTER

SECTIONS

1	FRAME
2	ENGINE ASSEMBLY
3	FUEL SYSTEM
4	ELECTRICAL SYSTEM
5	TRANSMISSION
6	DRIVE AXLE
7	STEERING SYSTEM
8	BRAKE SYSTEM
9	HYDRAULIC SYSTEM
10	MAST-TWO STAGE VISTA
11	ATTACHMENTS
12	OPTIONS
13	FIELD CONVERSION KITS
14	NUMERICAL INDEX

This Parts Manual is divided into 14 major sections which are listed above. Quick reference to these sections can be made by placing the right thumb on the tab of the desired section, bending the book back and thumbing the pages to the corresponding tab.

**Thanks very much for your reading,
Want to get more information,
Please click here, Then get the complete
manual**

JustClickHere 

NOTE:

**If there is no response to click on the link above,
please download the PDF document first, and then
click on it.**

**Have any questions please write to me:
admin@servicemanualperfect.com**

TABLE OF CONTENTS

DESCRIPTION	PAGE
A	
ACCUMULATOR	9-13
AIR CLEANER ASSEMBLY	3-8
AIR CONDITIONER	
CLIMATE CONTROL CAB - MCC	1-152
AIR CONDITIONER AND AIR DUCT	
WITHOUT CONDENSER	1-68
AIR CONDITIONER ASSEMBLY	
WITHOUT CONDENSER - MCC	1-74
AIR CONDITIONER SYSTEM	
CLIMATE CONTROL CAB - MCC	1-150
WITHOUT CONDENSER - MCC	1-70
AIR CONDITIONING COMPRESSOR	
→ 9/2008	2-8
AIR DUCT	
LOUVER, CLIMATE CONTROL CAB	1-144
AIR DUCT ASSEMBLY	
AIR CONDITIONING - WITH TWO-FAN CONDENSER SYSTEM, MCC	1-72
HEATER - WITH TWO-FAN CONDENSER SYSTEM, MCC	1-88
AIR HEATER	2-10
AIR INTAKE CONNECTION	2-12
AIR INTAKE HOSE	2-13
AIR INTAKE MANIFOLD	2-14
AIR INTAKE SYSTEM	3-6
AIR TRANSFER CONNECTION	2-15
AIRCO AIR COMPRESSOR KIT	13-2
ALTERNATOR AND MOUNTING	4-139
ALTERNATOR SUPPORT AND WATER INLET	
→ 11/2008	4-141
11/2008 →	4-142
ARMREST ASSEMBLY	
HYDRAULIC LEVERS	1-136
JOYSTICK	1-138
B	
BELT TENSIONER	2-16
BOW-SHACKLES	12-10
BRAKE AND INCHING PEDAL LINKAGE	8-12
BRAKE SYSTEM	
1/2011 →	8-8
PAGE 1 OF 2 (→ 1/2011)	8-2
PAGE 2 OF 2 (→ 1/2011)	8-6
BRAKE TEMPERATURE SWITCH	13-2
BRAKE VALVE	
WET BRAKE	8-14
C	
CAB	
CLOSED - SHEET 1 OF 2	1-4

TABLE OF CONTENTS (continued)

DESCRIPTION	PAGE
CLOSED - SHEET 2 OF 2	1-6
MAIN DOOR WINDOW - RIGHT AND LEFT HAND	1-64
OPEN - SHEET 1 OF 2	1-8
OPEN - SHEET 2 OF 2	1-10
CAB ASSEMBLY	
CLIMATE CONTROL CAB	1-154
CAB ATTACHING PARTS	1-24
CAB DOOR ATTACHING PARTS	1-28
CAB FLOORMATS	1-30
CAB HEATER PLUMBING	2-17
CAB HOSES AND ATTACHING PARTS	9-6
CAB LEFT HAND DOOR	
→ S/N A236E01737G (CLOSED CAB WITH AIR CONDITIONING)	
→ S/N A236E01735G (CLOSED CAB WITHOUT AIR CONDITIONING)	1-40
S/N A236E01736G → (CLOSED CAB WITHOUT AIR CONDITIONING)	
S/N A236E01738G → (CLOSED CAB WITH AIR CONDITIONING)	1-42
CAB PANELS	1-32
CAB RECIRCULATING FAN	
CLOSED CONSTRUCTION	1-34
CAB RIGHT HAND DOOR	
→ S/N A236E01737G (CLOSED CAB WITH AIR CONDITIONING)	
→ S/N A236E01735G (CLOSED CAB WITHOUT AIR CONDITIONING)	1-36
S/N A236E01736G → (CLOSED CAB WITHOUT AIR CONDITIONING)	
S/N A236E01738G → (CLOSED CAB WITH AIR CONDITIONING)	1-38
CAB SOUND REDUCTION	1-44
CAB SUNSHADE	
REAR	1-46
TOP	1-45
CAB TILT AND LATCH ASSEMBLY	1-50
CAB TILT CYLINDER	1-56
CAB TILT ELECTRIC PUMP	1-52
CAB TILT HAND PUMP	1-54
CAB WINDOWS INSTALLATION	1-58
CAMSHAFT	2-18
CAPSULE ASSEMBLY	
RAISE AND LOWER - JOYSTICK AND LEVERS	9-52
TILT - JOYSTICK AND LEVERS	9-54
CARRIAGE	
PIN TYPE	10-24
QUICK DISCONNECT TYPE	10-28
CARRIAGE HYDRAULICS	10-32
CASE AND REAR COVER	5-36
CHARGING PUMP	5-24
CLIMATE CONTROL SYSTEM	
MCC	1-148
COMBINATION VALVE	9-24
COMPRESSOR ASSEMBLY	
WITH TWO-FAN CONDENSER SYSTEM - MCC	1-90

TABLE OF CONTENTS (continued)

DESCRIPTION	PAGE
CONDENSER ASSEMBLY	
AURORA (→ 9/2008)	1-92
MCC (9/2008 →)	1-94
CONDENSER HOSES AND ATTACHING PARTS	
→ 9/2008	1-96
9/2008 ↔ 6/2009	1-98
6/2009 →	1-100
CONNECTING RODS AND PISTONS	
→ 11/2008	2-20
11/2008 →	2-22
CONSOLE	
INDICATOR DISPLAY AND CONTROLS	4-8
CONTROL PANEL	
AIR CONDITIONER	4-12
HEATER	4-10
CONTROL PANEL ASSEMBLY	
WITHOUT CONDENSER - MCC	1-76
CONTROL VALVE	9-26
AUXILIARY SPOOL SECTION	9-36
LIFT SPOOL SECTION - 1A AND 1B	9-32
LIFT SPOOL SECTION - 4A AND 4B	9-34
MID-INLET SECTION	9-28
OUTLET SECTION	9-29
TILT SPOOL SECTION	9-30
CONTROL VALVE ASSEMBLY	5-30
CONTROL VALVE ATTACHING PARTS	5-28
CONVERTER HOUSING	5-4
COOLANT HEATER STARTING AID	2-24
COOLING SYSTEM	2-4
COUNTERWEIGHTS	1-20
CRANKCASE BREATHER	2-32
CRANKSHAFT AND BEARINGS	
→ 11/2008	2-26
11/2008 →	2-30
CYLINDER BLOCK	
→ 11/2008	2-34
11/2008 →	2-36
CYLINDER HEAD	
→ 11/2008	2-38
11/2008 →	2-40
D	
DASH AND AIR DUCT ASSEMBLY	1-65
DC-DC CONVERTER AND ATTACHING PARTS	4-16
DELUXE SUSPENSION SEAT	1-108
DIRECTIONAL AND MARKER LIGHTS	12-3
DRIVE AXLE	
CARRIER ASSEMBLY (→ S/N A236E01525E)	6-6
CARRIER ASSEMBLY (S/N A236E01526E →)	6-10

TABLE OF CONTENTS (continued)

DESCRIPTION	PAGE
HUB AND SHAFT	6-12
DRIVE AXLE HOUSING	
→ S/N A236E01525E	6-2
S/N A236E01526E →	6-4
DRIVE PLATES	5-6
DRIVE TIRE AND WHEEL	
BRIDGESTONE	6-15
MICHELIN	6-16
SIMEX	6-19
TRELLEBORG - SOLID TIRE	6-17
TRELLEBORG	6-18
TRELLEBORG TR900	6-20
E	
ELECTRIC HORN	4-151
ELECTRICAL SYSTEM	4-4
EMPTY SEAT ENGINE SHUTDOWN	
3/2010 →	12-13
ENGINE ASSEMBLY	2-3
ENGINE BLOCK HEATER	2-42
ENGINE CONTROL MODULE	
→ 11/2008	4-144
11/2008 →	4-146
ENGINE COOLANT VENT	2-44
ENGINE FUEL PRESSURE SENDER	13-2
ENGINE MOUNTS	2-45
ENGINE OIL COOLER	2-46
ENGINE OIL PRESSURE SENDER KIT	13-2
ETR MODULE WIRING	
→ 11/2008	4-148
11/2008 →	4-149
EXHAUST MANIFOLD	2-48
EXHAUST SYSTEM	2-6
F	
FAN DRIVE AND MOUNTING	2-49
FAN SPACER	2-51
FENDER PLUGS	
WITHOUT FRONT LIGHT BRACKETS (S/N A236E01602F →)	4-22
FLOORPLATES AND COVERS	1-12
FLUID INDICATOR AND ATTACHING PARTS	5-39
FLYWHEEL AND MOUNTING	2-56
FLYWHEEL HOUSING	
→ S/N 73037048 (ENGINE)	2-52
S/N 73037049 → (ENGINE)	2-54
FORK	
PIN TYPE	11-4
FORK POSITIONER	
SIDE-SHIFT CYLINDER - QUICK DISCONNECT TYPE	10-34

TABLE OF CONTENTS (continued)

DESCRIPTION	PAGE
FORKS	
QUICK DISCONNECT TYPE	11-2
FORWARD AND THIRD SHAFT	5-18
FRONT GEAR COVER	2-57
FRONT LIGHTS	4-20
FUEL FILTER	3-16
FUEL FILTER PLUMBING	3-18
FUEL INJECTION PUMP	3-24
FUEL INJECTOR PLUMBING	3-22
FUEL INJECTORS	
→ 11/2008	3-19
11/2008 →	3-20
FUEL INLET FITTING	3-26
FUEL PLUMBING	
→ 11/2008	3-28
11/2008 →	3-30
FUEL SUPPLY SYSTEM	3-2
FUEL SYSTEM ACCESSORIES	3-32
G	
GEAR PUMP	9-16
GEARS	5-8
H	
HEADER HOSES	10-20
HEATED TOP WINDOW	
CLIMATE CONTROL CAB	12-12
HEATER AND AIR CONDITIONER ASSEMBLY	
WITH THREE-FAN CONDENSER SYSTEM - AURORA	1-80
HEATER AND AIR CONDITIONER MOUNTING	
WITH THREE-FAN CONDENSER SYSTEM - AURORA	1-78
HEATER AND AIR DUCT	
WITH TWO-FAN CONDENSER SYSTEM - MCC	1-84
HEATER AND CONTROL PANEL ASSEMBLIES	1-160
HEATER ASSEMBLY	
WITH THREE-FAN CONDENSER SYSTEM - AURORA	1-82
WITH TWO-FAN CONDENSER SYSTEM - MCC	1-86
HEATER HOSES AND ATTACHING PARTS	1-66
HEATER SYSTEM	
WITH TWO-FAN CONDENSER SYSTEM - MCC	1-85
HOODS AND COVERS	1-16
HYDRAULIC LEVERS	9-38
HYDRAULIC LEVERS HOSE ASSEMBLY	9-40
HYDRAULIC OIL COOLER	
BRAKE	9-7
HYDRAULIC SYSTEM	
CHASSIS SUPPLY AND RETURN	9-2
HYDRAULIC TANK	9-10
HYDRAULIC VALVES AND ATTACHING PARTS	9-20

TABLE OF CONTENTS (continued)

DESCRIPTION	PAGE
I	
INNER MAST	10-2
INPUT SHAFT AND FIRST CLUTCH	5-10
INSULATION MATS AND AIR DUCT CLIMATE CONTROL CAB	1-142
J	
JOINT MECHANISM ASSEMBLY	
JOYSTICK	9-44
LEVERS	9-43
JOYSTICK ASSEMBLY	9-48
JOYSTICK HOSE ASSEMBLY	9-50
JOYSTICK INSTALLATION	9-46
JUMP START AID	12-11
L	
LABELS	
HYDRAULIC CONTROLS	1-106
PAGE 1 OF 2	1-102
PAGE 2 OF 2	1-104
LIFT ACCUMULATOR SYSTEM	9-12
LIFT CYLINDER	
H400HD, HDS	10-42
H450HD, HDS	10-44
LIFTING BRACKETS AND MOUNTING	2-58
LIGHT ASSEMBLY	
HALOGEN	4-18
HIGH INTENSITY DISCHARGE	4-19
LIGHTS	
WORK - HALOGEN	4-25
WORK - HID	4-26
LOCKABLE DISCONNECT SWITCH LEVER	12-6
LOCKOUT LEVER	4-7
LOUVER - HEAVY DUTY AIRCO	13-2
LUBRICATING OIL PUMP	2-59
M	
MAIN LIFT	
SHEET 1 OF 2	10-10
SHEET 2 OF 2	10-14
MAIN VALVE HOSES	9-18
MAP READING LIGHT	
CLOSED CONSTRUCTION	12-5
MAST HOSE SHEAVE KIT	13-2
MAST INSTALLATION	10-18
MAST SUPPLY AND RETURN	9-4
MAST WORK LIGHTS	4-24
MIRRORS	1-26
MODULATOR VALVE ASSEMBLY	5-34
MONOTROL PEDAL	3-14

TABLE OF CONTENTS (continued)

DESCRIPTION	PAGE
MONOTROL PEDAL LINKAGE	3-12
MUDFLAPS AND ATTACHING PARTS	12-8
O	
OIL COOLER KIT	
OIL FILLER	2-60
OIL LEVEL GAUGE	2-61
OIL PAN	2-62
OPTIONAL MOUNTING EQUIPMENT (HANDLE)	12-2
OUTER MAST	10-6
OUTPUT SHAFT	5-26
OVERHEAD GUARD	
WIRE MESH	1-22
P	
PARK BRAKE ASSEMBLY	8-18
PARK BRAKE SWITCH REPLACEMENT	13-2
PILOT SUPPLY VALVE ASSEMBLY	
JOYSTICK	9-42
LEVERS	9-41
PIVOT ARM ASSEMBLY	1-140
PUMP DRIVE	5-22
R	
RADIATOR AND COOLER ASSEMBLY	2-64
RADIO CONSOLE AND ATTACHING PARTS	
CLOSED CAB ONLY	1-158
REAR GEAR HOUSING	2-66
REAR GEAR TRAIN ACCESSORY MOUNTING COVER	2-67
REAR LIGHTS AND BACK-UP ALARM	4-23
REGULATOR VALVE ASSEMBLY	5-32
RELAYS AND FUSES	
OPERATOR COMPARTMENT (→ 3/2008)	4-30
OPERATOR COMPARTMENT (3/2008 ↔ S/N A236E01753H)	4-34
OPERATOR COMPARTMENT (S/N A236E01754H →)	4-38
REMOTE OIL FILTER	2-68
REVERSE AND SECOND CLUTCH	5-14
ROCKER LEVERS	2-70
S	
SEAT ASSEMBLY	
CLIMATE CONTROL CAB	1-146
SEAT SUSPENSION ASSEMBLY	
AIR SUSPENSION	1-128
MECHANICAL AND AIR SUSPENSION	1-125
MECHANICAL SUSPENSION	1-132
SECOND 12V SOCKET OPTION	
CLIMATE CONTROL CAB	4-150
SELECTOR VALVE	10-36
STARTER MOTOR AND MOUNTING	2-72

TABLE OF CONTENTS (continued)

DESCRIPTION	PAGE
STEER AXLE ASSEMBLY	7-10
STEER COLUMN	7-6
STEER COLUMN AND ATTACHING PARTS	7-2
STEER COLUMN ASSEMBLY	7-4
STEER CYLINDER	7-14
OPTIONAL	7-16
STEER PUMP ASSEMBLY	7-8
STEER TIRE AND WHEEL	
BRIDGESTONE	7-18
MICHELIN	7-19
SIMEX	7-22
TRELLEBORG - SOLID TIRE	7-20
TRELLEBORG	7-21
TRELLEBORG TR900	7-23
STEERING CONTROL UNIT ASSEMBLY	7-24
STEERING HOSES AND ATTACHING PARTS	9-8
STROBE LIGHT	12-4
SUSPENSION KIT ASSEMBLY	1-110
SUSPENSION SEAT	
WITH FABRIC COVER (→ 3/2010)	1-114
WITH FABRIC COVER (3/2010 →)	1-118
WITH VINYL COVER	1-122
SWITCHES	4-27
T	
TELEMETRY KITS	13-3
THERMOSTAT	2-73
THROTTLE PEDAL AND LINKAGE	
FORWARD AND REVERSE LEVER	3-10
TILT CYLINDER HYDRAULICS	10-40
TILT CYLINDERS	10-38
TILT PLATFORM ASSEMBLY	1-48
TORQUE CONVERTER	5-7
TORQUE CONVERTER COOLER PLUGS	2-74
TRAINING SEAT	1-156
TRANSMISSION ASSEMBLY	5-2
TRANSMISSION CONTROLLER AND SHIFT LEVER	4-14
TRANSMISSION HOSES AND ATTACHING PARTS	5-42
TRANSMISSION MOUNTING	5-44
TURBOCHARGER	
→ 11/2008	2-76
11/2008 →	2-79
TURBOCHARGER PLUMBING	
→ 11/2008	2-80
11/2008 →	2-82
U	
UNIVERSAL SHAFT	5-40

TABLE OF CONTENTS (continued)

DESCRIPTION	PAGE
V	
VALVE COVER	
→ 11/2008	2-84
11/2008 →	2-86
VALVE TAPPETS	2-87
VIBRATION DAMPER	2-88
W	
WATER OUTLET CONNECTION	
11/2008 →	2-91
WATER PUMP	2-89
WATER PUMP DRIVE	2-90
WET BRAKE ASSEMBLY	8-16
WINDOW WIPER SYSTEM	
REAR AND ROOF WIPER KITS - AND FRONT WIPER OPTIONS	1-62
WASHER BOTTLE KIT	1-60
WIPER REPAIR	13-2
WIRE HARNESS	
AIR CONDITIONER EXTENSION (S/N A236E01683F ↔ 1/2010 INC. 01681)	4-138
ARM REST	4-42
CAB LIGHTS	4-46
CAB SIDE CONSOLE - SHEET 1 OF 3 (→ 3/2008)	4-48
CAB SIDE CONSOLE - SHEET 2 OF 3 (→ 3/2008)	4-52
CAB SIDE CONSOLE - SHEET 3 OF 3 (→ 3/2008)	4-56
CAB SIDE CONSOLE - SHEET 1 OF 3 (3/2008 ↔ S/N A236E01753H)	4-58
CAB SIDE CONSOLE - SHEET 2 OF 3 (3/2008 ↔ S/N A236E01753H)	4-62
CAB SIDE CONSOLE - SHEET 3 OF 3 (3/2008 ↔ S/N A236E01753H)	4-66
CAB SIDE CONSOLE - SHEET 1 OF 3 (S/N A236E01754H →)	4-68
CAB SIDE CONSOLE - SHEET 2 OF 3 (S/N A236E01754H →)	4-72
CAB SIDE CONSOLE - SHEET 3 OF 3 (S/N A236E01754H →)	4-76
CAB UNDERFLOOR	4-78
CHASSIS - SHEET 1 OF 2 (→ S/N A236E01601F)	4-84
CHASSIS - SHEET 2 OF 2 (→ S/N A236E01601F)	4-88
CHASSIS - SHEET 1 OF 2 (S/N A236E01602F ↔ S/N A236E01668F)	4-92
CHASSIS - SHEET 2 OF 2 (S/N A236E01602F ↔ S/N A236E01668F)	4-96
CHASSIS - SHEET 1 OF 2 (S/N A236E01669F ↔ 1/2010)	4-100
CHASSIS - SHEET 2 OF 2 (S/N A236E01669F ↔ 1/2010)	4-104
CHASSIS - SHEET 1 OF 2 (1/2010 →)	4-108
FRONT END EQUIPMENT - MAST REAR HEADER HOSES	4-132
FRONT END EQUIPMENT - MAST FRONT HEADER HOSES	4-134
FRONT LIGHTS (→ S/N A236E01601F)	4-119
FRONT LIGHTS (S/N A236E01602F →)	4-120
HYDRAULIC LEVERS SWITCHES	4-153
HYDRAULIC RELAYS	4-80
MAST WORK LIGHT - LEFT HAND	4-122
MAST WORK LIGHT - RIGHT HAND	4-123
MAST WORK LIGHTS - SUPPLY	4-121
OIL COOLER (→ S/N A236E01682F)	4-124
OIL COOLER (S/N A236E01683F →)	4-126

TABLE OF CONTENTS (continued)

DESCRIPTION	PAGE
OPEN AND CLOSED CAB	4-116
POWERED CAB TILT	4-128
REAR	4-156
REAR WIPER EXTENSION	4-129
SEALED FUSE BOX	4-28
SELECTOR VALVE - TWO FUNCTION	4-158
SELECTOR VALVE - THREE TO FIVE FUNCTION	4-160
SIDE AND INDICATOR LIGHTS - ALTERNATE PART	4-137
SIDE INDICATOR	4-136
STEERING COLUMN	4-130
WINDOW WASH PUMPS	4-152
WIRE HARNESS (CHASSIS)	
SHEET 2 OF 2 (1/2010 →)	4-112

ABBREVIATIONS QUICK REFERENCE SHEET

Listed below are abbreviations used in parts manuals to denote the following expressions:

TERM	DEFINITION	TERM	DEFINITION
Amp	Amperes	FRE	Freezer Environment
AR	As Required	in.	inches
BDI	Battery Discharge Indicators	LPG	Liquefied Petroleum Gas
BWI	Brush Wear Indicator	MAP	Manifold Absolute Pressure
CE	Communicator End	mm	millimeters
CRE	Corrosive Environment	MSTS	Microprocessor Spark Timing System
D/B	Date Break	NPT	National Pipe Threads
dbA	Decibel "A" Scale	O/S	Oversize
DE	Drive End	PTO	Power Take Off
ECH	Empty Container Handler	RPM	Revolutions per Minute
ECH-3	Empty Container Handler - 3 High Stacking	S/N	Serial Number
ECH-4	Empty Container Handler - 4 High Stacking	TMM	Truck Management Module
ECH-5	Empty Container Handler - 5 High Stacking	UL Type D	Diesel-Powered Safety Rating
ECH-6	Empty Container Handler - 6 High Stacking	UL Type DS	Diesel-Powered Safety Rating
ECH-7	Empty Container Handler - 7 High Stacking	UL Type E	Battery-Powered Safety Rating
ECM	Electronic Control Module	UL Type EE	Battery-Powered Safety Rating
ECN	Engineering Change Notice	UL Type ES	Battery-Powered Safety Rating
EEPROM	Electrically Erasable Programmable Read Only Memory	UL Type G	Gasoline-Powered Safety Rating
EPA	US Environmental Protection Agency	UL Type GS	Gasoline-Powered Safety Rating
EPROM	Electrically Programmable Read Only Memory	UL Type LP	Gas-Powered Safety Rating
		UL Type LPS	LP Gas-Powered Safety Rating
		U/S	Undersize
		UL	Underwriters Laboratory
		V	Volts

HOW TO USE THE ILLUSTRATED PARTS MANUAL

This parts manual describes and illustrates assemblies, subassemblies, and detail parts needed for service replacement.

The different constructions are indicated by keys and footnotes. The callouts correspond to descriptions found on the next page.

HYSTER UNIT CODE D001 NORTH AMERICA 06/2001

TABLE OF CONTENTS

DESCRIPTION	PAGE
AIR INTAKE AND FILTER DIESEL (⇒ D/B 11/98)	3-22
AIR INTAKE AND FILTER DIESEL (D/B 11/96 ⇒)	
AIR INTAKE AND FILTER GASOLINE AND LPG	
ALTERNATOR GASOLINE, LPG, AND DIESEL	
ALTERNATOR TYPES GS, LPS, AND DS	
AUXILIARY FUNCTION TUBE TWO AND THREE STAGE FULL F	

SECTION 13 NUMERICAL INDEX

PART NO.	PAGE NO.	ITEM NO.	PART NO.	PAGE NO.	ITEM NO.	PART NO.	PAGE NO.	ITEM NO.	PART NO.	PAGE NO.	ITEM NO.
142	3-4	19	10-13	25		11-27	29	12-31	12		
12445	3-32	19	10-17	6		11-31	25	16719	3-36	5	
	3-34	1	10-27	11		11-32	37	16751	3-16	27	
			11	11		8-4	29	16849	3-34	21	
			11	6	16485	8-4	45		3-38	20	
			12	13		8-4	45	16863	3-28	17	
			14	6		8-8	34	16865	3-6	18	
			12	6		9-7	9		4-27	41	
			3	17		9-7	19	16882	9-7	30	
			9	10		9-11	9		9-11	27	
			23	46		9-11	17		10-10	36	
			27	46		10-9	21		10-13	32	
			26	14		10-9	28		11-7	24	
			28	14		10-13	16		11-9	17	
			50	14		11-7	19				

SECTIONS

- FRAME
- ELECTRICAL SYSTEM
-
-
- BRAKE/ACC
-
- MAST-TWO STAG
- MAST-THREE STAG
- MAST-TWO STAG
-
-

TRANSMISSION HOUSING ⇒ S/N D001H-2628

KEY:
A: Diesel
B: Gasoline and LPG

ITEM	PART NO.	DESCRIPTION	QTY	
			A	B
1	202547	Transmission	1	1
2	2023329	Transmission	1	1
3	2021670	Case	2	2
4	2023418	Bearing Cap	4	4
5	296429	Washer	4	4
6	293947	Bolt	1	1
7	2021390	Cover	2	2
8	1371656	Colter Pin	4	4
9	2021915	O-Ring	1	1
10	2021329	Plug	4	4
11	2021675	Housing	22	22
12	2021336	Pin	39	39
13	287860	Bolt	1	1
14	292682	Lockwasher	1	1
15	2021345	Hydraulic Pump	1	1
16	214364	⇒ Figure 5-3	1	1
17	296418	Gasket	1	1
18	2021388	Bolt	1	1
19	2021389	Washer	1	1
20	292531	Temperature Switch	1	1
21	292583	Breather	9	9
22	293637	Dipstick	9	9
23	296420	Bolt	2	2
24	996403	Nut	3	3
25	996405	Bolt	3	2
26		Capcrew	4	4
		Lockwasher	4	4
		Bolt	4	4
		Washer	1	1
		Transmission Kit (Includes Item 7)	1	1
		Transmission Kit (Includes Item 14)	1	1

This Parts Manual is divided into 11 major sections which are listed above. Quick be made by placing the right thumb on the tab of the desired section, bending the pages to the corresponding tab.

© Copy Right Date HYSTER COMPANY See Service Manual for service procedures. 5-15

HP990004

HOW TO FIND THE DESIRED PART NUMBER

WHEN THE PART NUMBER AND THE NEXT HIGHER ASSEMBLY IS NOT KNOWN:

1. Determine the function and application of the part required. Turn to the Sections Page. Choose the general area of reference most likely to include the part.
2. Turn to the section you chose. Use the Section Table of Contents to determine the assembly which would normally contain the part required. Then locate the part on the assembly breakdown page.

WHEN THE PART NUMBER IS NOT KNOWN AND THE NEXT HIGHER ASSEMBLY IS KNOWN:

3. Determine the assembly the required part is used on. Turn to the Table of Contents (Page i).
4. Locate the assembly the required part is used on and turn to the page indicated for that assembly. Then locate the part on the assembly breakdown page.

WHEN THE PART NUMBER IS KNOWN:

5. Use the Numerical Index (Page 14-1) to find the part number. Turn to the page listed and locate the part as indicated by the item number.

GENERAL:

The assembly breakdowns include part numbers, descriptions, quantities required, keys and footnotes to help in selecting correct parts.

6. Parts Supersession Information. Part numbers that have this history will be displayed in the parts list in the order that they were superseded (from oldest to newest). The superseded part numbers will be shown with a line through them.

Five periods in the PART NO. column (.) indicate that the part is either *Not Serviced Separately* or there is a reference to another figure. A figure reference is denoted by a pointing hand followed by a figure number in the DESCRIPTION column (☞ Figure 10)

7. Keys are used to show two or more similar assemblies, RH and LH assembly parts, etc. Select the appropriate key, "A", "B", "C", "D", or "E" and the corresponding quantity column to find the required parts. Two periods in the QTY column (..) indicate that the part is not used for that assembly.
8. Indented descriptions under the DESCRIPTION column are used to indicate assemblies and

subparts of assemblies. In the example on the previous page, *BEARING CAP* (Item 2) is a subpart of the major assembly *CASE*.

9. Quantities shown are for one assembly. The quantities of the subpart *BEARING CAP* are indicated as two and two. This means two per *CASE* assembly.
10. Serial number breaks identify the most current parts information and are shown as follows:
 - **S/N D001H2628**
Indicates last serial number affected.
 - S/N D001H2629** →
Indicates the first serial number affected.
 - S/N D001H1553** ↔ **S/N D001H3291**
Indicates a range of serial numbers affected.

ECN numbers for pending serial numbers are shown to allow for the inclusion of the most current parts information and are identified as follows:

→ **S/N Pending Per ECN 63243**

Indicates a pending serial number for last unit affected.

S/N Pending Per ECN 63243 →

Indicates a pending serial number for first unit affected.

Date breaks are used to indicate when a change occurred but a subsequent serial number break was not recorded. This is an arbitrary date usually based on the ECN release and are identified as follows:

→ **D/B 3/00**

Indicates that a change occurred sometime within that month for the item affected.

D/B 3/00 →

Indicates that a change occurred sometime within that month for the item affected.

D/B 3/00 ↔ **D/B 4/00**

Indicates a range of production dates of the item affected.

Contact your local dealer for Hyster lift trucks for serial number information for items with a ECN or a date break.

ORDERING PARTS:

When ordering replacement parts, give the unit serial number, part number, name of part and quantity required.

For any further information on parts, service, or ordering, consult your local dealer for Hyster lift trucks.

IDENTIFICATION OF TRUCK SERIAL NUMBERS

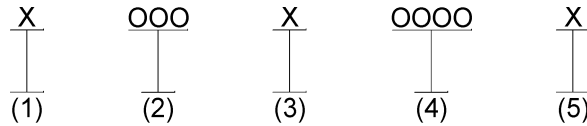

- (1) and (2) The first letter and three numbers indicate the truck unit code.
- (3) The second letter indicates the plant of manufacture.
- (4) The four or five digit number indicates the production sequence number of the truck.
- (5) The final letter indicates the year of manufacture starting with "A" in 1957, 1980, and 2003.
The letters "I", "O", and "Q" will not be used.

For pending serial numbers contact your local dealer for Hyster lift trucks.

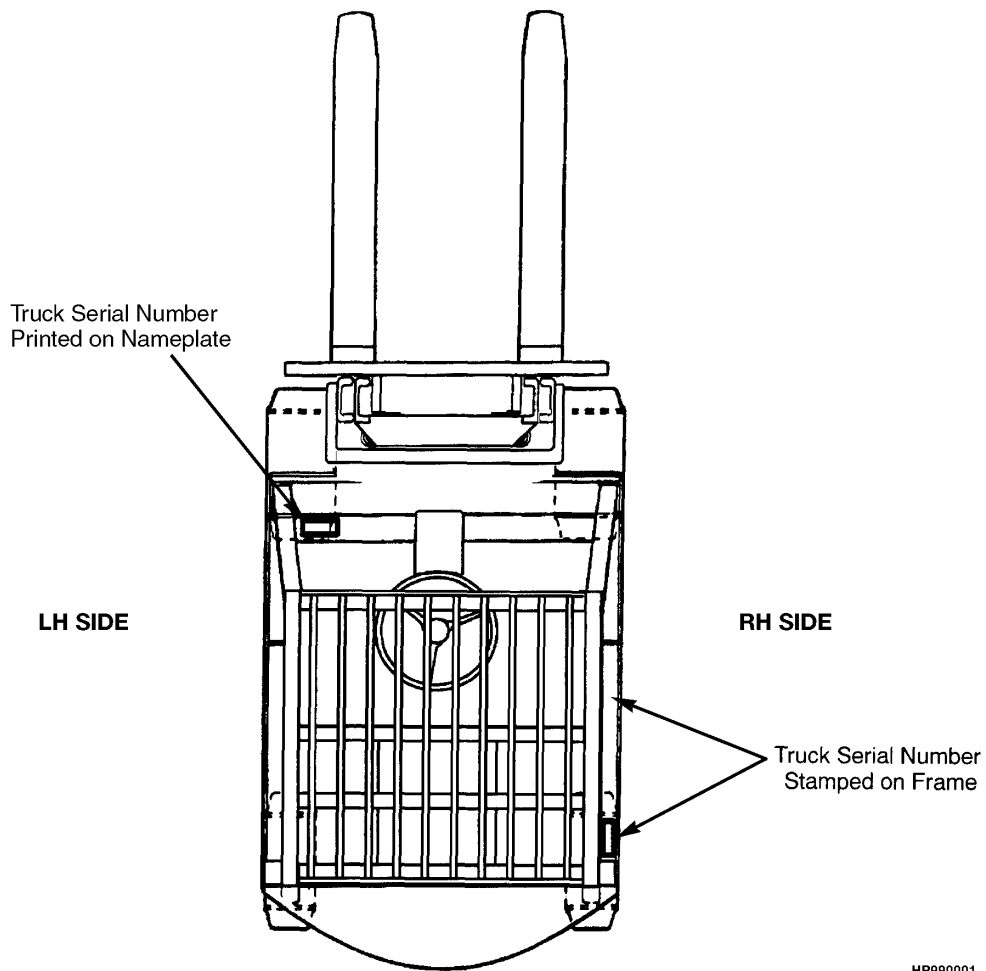

HP990001

Parts referred to in this book as right or left hand parts are in accordance with the illustration above.

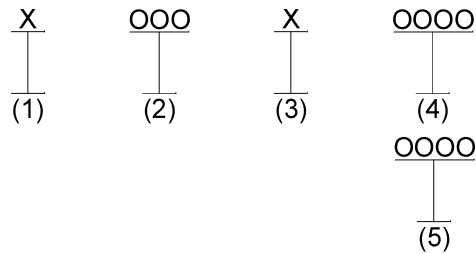
IDENTIFICATION OF MAST SERIAL NUMBERS

- (1) and (2) The first letter and number indicates the mast unit code.
- (3) The second letter indicates the plant of manufacture.
- (4) The four or five digit number indicates the production sequence number of the mast.
- (5) Carriage travel in millimeters stamped just below the serial number.

Mast Group identification consists of mast unit code (1) and (2) plus carriage travel (5).

For pending production sequence numbers contact your local dealer for Hyster lift trucks.

LIFT EQUIPMENT IDENTIFICATION

1. Fork part number, capacity rating, plant code letter, and date of manufacture are stamped approximately six inches below the top of most forks.
2. The carriage group number is stamped on the right hand side of the top crossmember (pin type) or on the back of the right hand end of the bottom crossmember (hook type). A date code has two letters in line with or below the carriage group number.
3. The mast identification number has a unit code, a letter indicating the plant of manufacture, and a serial number. Underneath the production sequence number is a four digit number that indicates the carriage travel in millimeters.
4. Tilt and lift cylinder group numbers are stamped on the cylinder shell.

Always refer to the group, serial, or part number when ordering service parts.

Modification of masts and carriages by SPED (Special Products Engineering Department) are identified by a model prefix code beginning with the letter "S". contact your dealer for Hyster lift trucks for information on these assemblies.

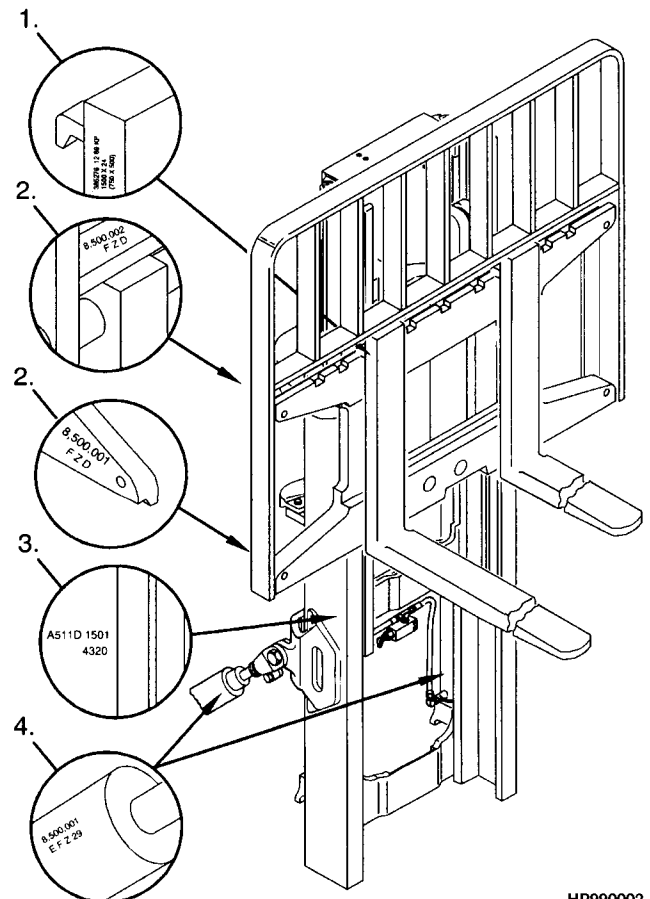

HP990002

IDENTIFICATION OF ATTACHMENT AND SIDE-SHIFT CARRIAGE SERIAL NUMBERS

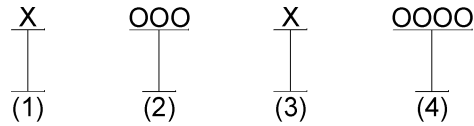

(1) and (2) The first letter and three numbers indicate the attachment unit code.

(3) The second letter indicates the plant of manufacture.

(4) The four or five digit number indicates the production sequence number.

For pending production sequence numbers contact your local dealer for Hyster lift trucks.

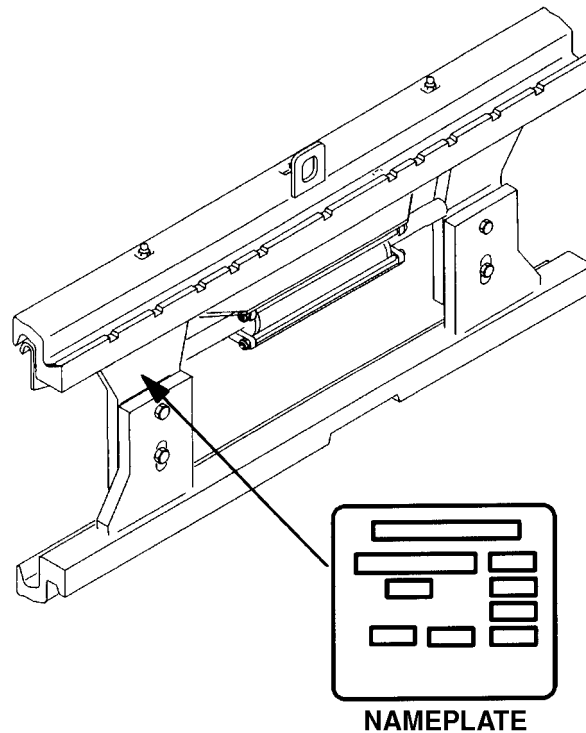

HP990003

Side-shift carriages and attachments have nameplates. Use the serial number found on the nameplate to identify the attachment.

Always refer to the group, serial, or part number when ordering service parts.

Modifications of attachments and side-shift carriages by SPED (Special Products Engineering Department) are identified by a model prefix code beginning with the letter "S". Contact your dealer for Hyster lift trucks for information on these assemblies.

PUBLICATIONS

Every new lift truck is provided with an OPERATING MANUAL. This manual has information that the operator must know for inspection and operation of the lift truck.

SERVICE MAINTENANCE MANUALS, which provide service and overhaul procedures, and PARTS

MANUALS with complete replacement part identification, are available at a nominal fee from your Hyster dealer to assist users in effectively maintaining Hyster lift trucks in a safe, useful condition. See the list below for information on ordering specific publications for this model lift truck.

PUBLICATION	HYSTER PART NUMBER
Operating Manual.....	1625129
Service Manual (Complete).....	1627712
Parts Manual.....	1650210

1

FRAME

SECTION 1
FRAME

DESCRIPTION	PAGE
AIR CONDITIONER	
CLIMATE CONTROL CAB - MCC	1-152
AIR CONDITIONER AND AIR DUCT	
WITHOUT CONDENSER	1-68
AIR CONDITIONER ASSEMBLY	
WITHOUT CONDENSER - MCC	1-74
AIR CONDITIONER SYSTEM	
CLIMATE CONTROL CAB - MCC	1-150
WITHOUT CONDENSER - MCC	1-70
AIR DUCT	
LOUVER, CLIMATE CONTROL CAB	1-144
AIR DUCT ASSEMBLY	
AIR CONDITIONING - WITH TWO-FAN CONDENSER SYSTEM, MCC	1-72
HEATER - WITH TWO-FAN CONDENSER SYSTEM, MCC	1-88
ARMREST ASSEMBLY	
HYDRAULIC LEVERS	1-136
JOYSTICK	1-138
CAB	
CLOSED - SHEET 1 OF 2	1-4
CLOSED - SHEET 2 OF 2	1-6
MAIN DOOR WINDOW - RIGHT AND LEFT HAND	1-64
OPEN - SHEET 1 OF 2	1-8
OPEN - SHEET 2 OF 2	1-10
CAB ASSEMBLY	
CLIMATE CONTROL CAB	1-154
CAB ATTACHING PARTS	1-24
CAB DOOR ATTACHING PARTS	1-28
CAB FLOORMATS	1-30
CAB LEFT HAND DOOR	
→ S/N A236E01737G (CLOSED CAB WITH AIR CONDITIONING)	
→ S/N A236E01735G (CLOSED CAB WITHOUT AIR CONDITIONING)	1-40
S/N A236E01736G → (CLOSED CAB WITHOUT AIR CONDITIONING)	
S/N A236E01738G → (CLOSED CAB WITH AIR CONDITIONING)	1-42
CAB PANELS	1-32
CAB RECIRCULATING FAN	
CLOSED CONSTRUCTION	1-34
CAB RIGHT HAND DOOR	
→ S/N A236E01737G (CLOSED CAB WITH AIR CONDITIONING)	
→ S/N A236E01735G (CLOSED CAB WITHOUT AIR CONDITIONING)	1-36
S/N A236E01736G → (CLOSED CAB WITHOUT AIR CONDITIONING)	
S/N A236E01738G → (CLOSED CAB WITH AIR CONDITIONING)	1-38
CAB SOUND REDUCTION	1-44
CAB SUNSHADE	
REAR	1-46
TOP	1-45
CAB TILT AND LATCH ASSEMBLY	1-50
CAB TILT CYLINDER	1-56
CAB TILT ELECTRIC PUMP	1-52
CAB TILT HAND PUMP	1-54

SECTION 1 FRAME

DESCRIPTION	PAGE
CAB WINDOWS INSTALLATION	1-58
CLIMATE CONTROL SYSTEM	
MCC	1-148
COMPRESSOR ASSEMBLY	
WITH TWO-FAN CONDENSER SYSTEM - MCC	1-90
CONDENSER ASSEMBLY	
AURORA (→ 9/2008)	1-92
MCC (9/2008 →)	1-94
CONDENSER HOSES AND ATTACHING PARTS	
→ 9/2008	1-96
9/2008 ↔ 6/2009	1-98
6/2009 →	1-100
CONTROL PANEL ASSEMBLY	
WITHOUT CONDENSER - MCC	1-76
COUNTERWEIGHTS	1-20
DASH AND AIR DUCT ASSEMBLY	1-65
DELUXE SUSPENSION SEAT	1-108
FLOORPLATES AND COVERS	1-12
HEATER AND AIR CONDITIONER ASSEMBLY	
WITH THREE-FAN CONDENSER SYSTEM - AURORA	1-80
HEATER AND AIR CONDITIONER MOUNTING	
WITH THREE-FAN CONDENSER SYSTEM - AURORA	1-78
HEATER AND AIR DUCT	
WITH TWO-FAN CONDENSER SYSTEM - MCC	1-84
HEATER AND CONTROL PANEL ASSEMBLIES	1-160
HEATER ASSEMBLY	
WITH THREE-FAN CONDENSER SYSTEM - AURORA	1-82
WITH TWO-FAN CONDENSER SYSTEM - MCC	1-86
HEATER HOSES AND ATTACHING PARTS	1-66
HEATER SYSTEM	
WITH TWO-FAN CONDENSER SYSTEM - MCC	1-85
HOODS AND COVERS	1-16
INSULATION MATS AND AIR DUCT	
CLIMATE CONTROL CAB	1-142
LABELS	
HYDRAULIC CONTROLS	1-106
PAGE 1 OF 2	1-102
PAGE 2 OF 2	1-104
MIRRORS	1-26
OVERHEAD GUARD	
WIRE MESH	1-22
PIVOT ARM ASSEMBLY	1-140
RADIO CONSOLE AND ATTACHING PARTS	
CLOSED CAB ONLY	1-158
SEAT ASSEMBLY	
CLIMATE CONTROL CAB	1-146
SEAT SUSPENSION ASSEMBLY	
AIR SUSPENSION	1-128
MECHANICAL AND AIR SUSPENSION	1-125

SECTION 1
FRAME

DESCRIPTION	PAGE
MECHANICAL SUSPENSION	1-132
SUSPENSION KIT ASSEMBLY	1-110
SUSPENSION SEAT	
WITH FABRIC COVER (→ 3/2010)	1-114
WITH FABRIC COVER (3/2010 →)	1-118
WITH VINYL COVER	1-122
TILT PLATFORM ASSEMBLY	1-48
TRAINING SEAT	1-156
WINDOW WIPER SYSTEM	
REAR AND ROOF WIPER KITS - AND FRONT WIPER OPTIONS	1-62
WASHER BOTTLE KIT	1-60